

Unified Collaborative Solutions Over IP

**Aarti Iyengar
Solutions Architect**



Agenda

- **Drivers**
- **Challenges**
- **What UCC is all about**
- **Network Requirements**
- **Industry Support**
- **Summary**

Drivers

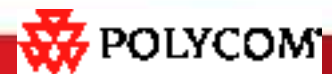

The move to IP Infrastructure

- **More and more Corporates & Enterprises are moving towards IP**
- **Yankee Group Enterprise IT survey**
 - 60 percent have already moved to an IP Network
 - 30 percent plan to do so in 12-24 months
- **IP is Ubiquitous**
 - But IP Networks are best effort
 - Now evolving to support every communications requirement
 - Universal access
 - Lower costs
- **Future**

“... in 7 to 10 years video traffic on the net will exceed data and voice traffic combined.”

Bob Metcalf, Forbes Magazine February 3, 2003

- **Are Extended Enterprises**
 - **Global**
 - **Networked**
 - **Distributed**
 - **Multiple locations**
 - **Across Geographies**
- **Have a flexible structure**
 - **Designed to move quickly**
 - **Need real-time communications**
- **Have decision making that is distributed and dynamic**

Challenges

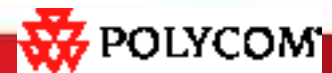

The Challenges to Collaboration

- **The Internet has helped productivity**
 - Instant Messaging / IP telephony show the way
 - Not designed to be a real-time communications medium
 - Need SLAs for collaborative multimedia applications
- **Decision makers are mobile and distributed**
 - Poor access to resources and efficient collaboration
- **End Users must be able to invoke multimedia services in real-time**
 - reservationless, real-time, ad-hoc meetings
- **Resolve barriers to adoption**
 - Make multimedia service offerings comfortable to learn and use
 - Guarantee performance
 - Create a converged multipurpose infrastructure

Multimedia Communications OR Unified Collaborative Communications



Unified Collaborative Communications (UCC)



- **Move from a collection of proprietary, single purpose networks**
- **To one, converged, multi-purpose infrastructure**
 - Voice
 - Video
 - Web
- **Communicate with one another**
 - Anywhere
 - Anytime
 - Across any medium
 - From multiple diverse endpoints
- **IP is the natural choice of protocol for unification**

UCC is Voice, Data and Video



Benefits

Increased Learning	Attendees learn 200% more in face-to-face meetings than with audio alone (Source: University of Wisconsin)
Improved Rate of Absorption	Attendees absorb information up to 40% faster than with audio alone (Source: Wharton School of Business)
Augmented Content Retention	Attendees in face-to-face meetings retain 38% more information than attendees in audio-only meetings (Source: Harvard University & Columbia University.)
Enhanced Persuasiveness	Face to face meetings increase the power of persuasion by 43% over audio-only meetings (Source: 3M Co.)
Improved Impact of Communication	55% of the impact of communications comes from facial expressions and body language, versus 38% from vocal inflection (Source: UCLA)

Current Architecture

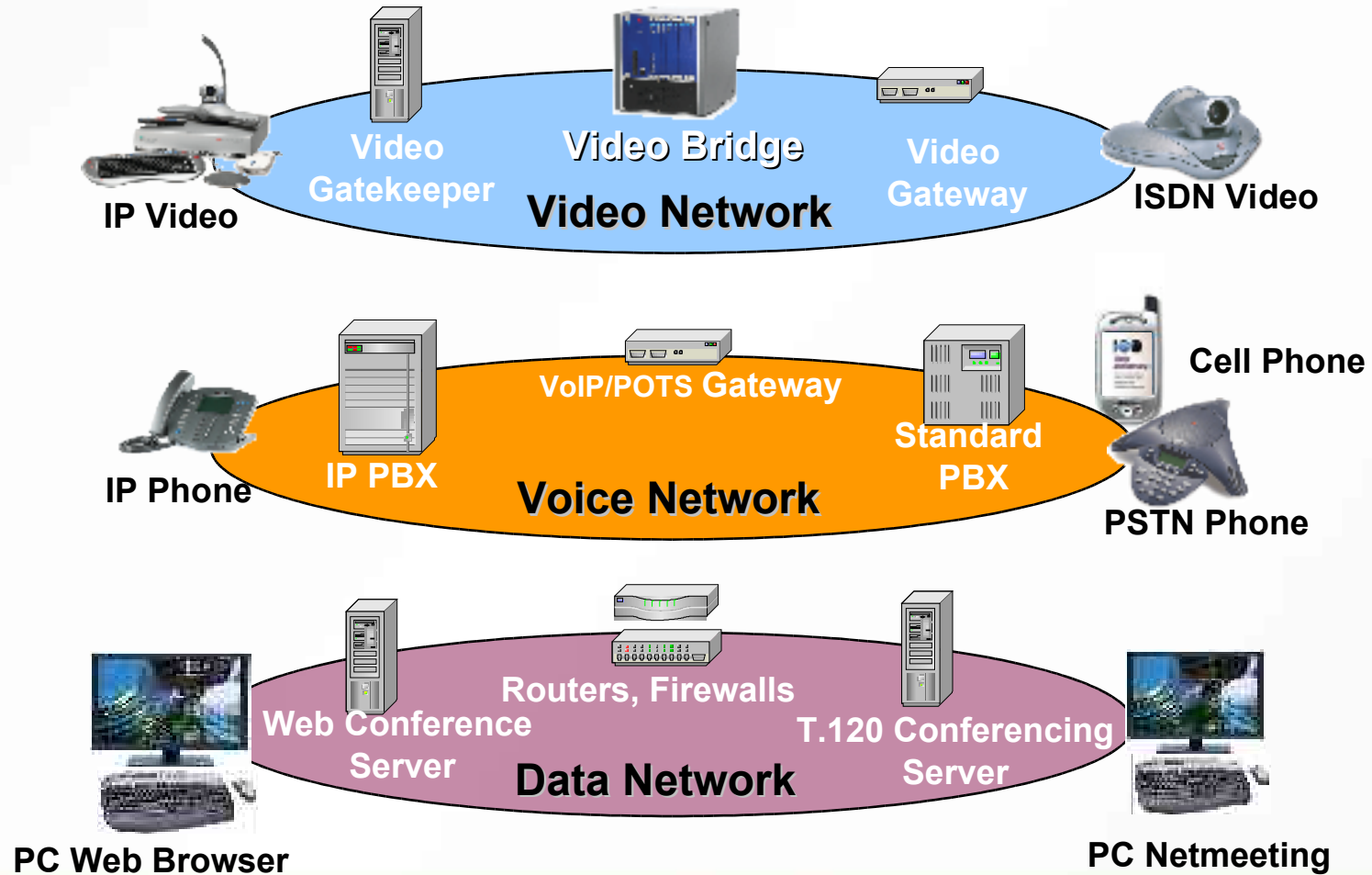

Current Architecture

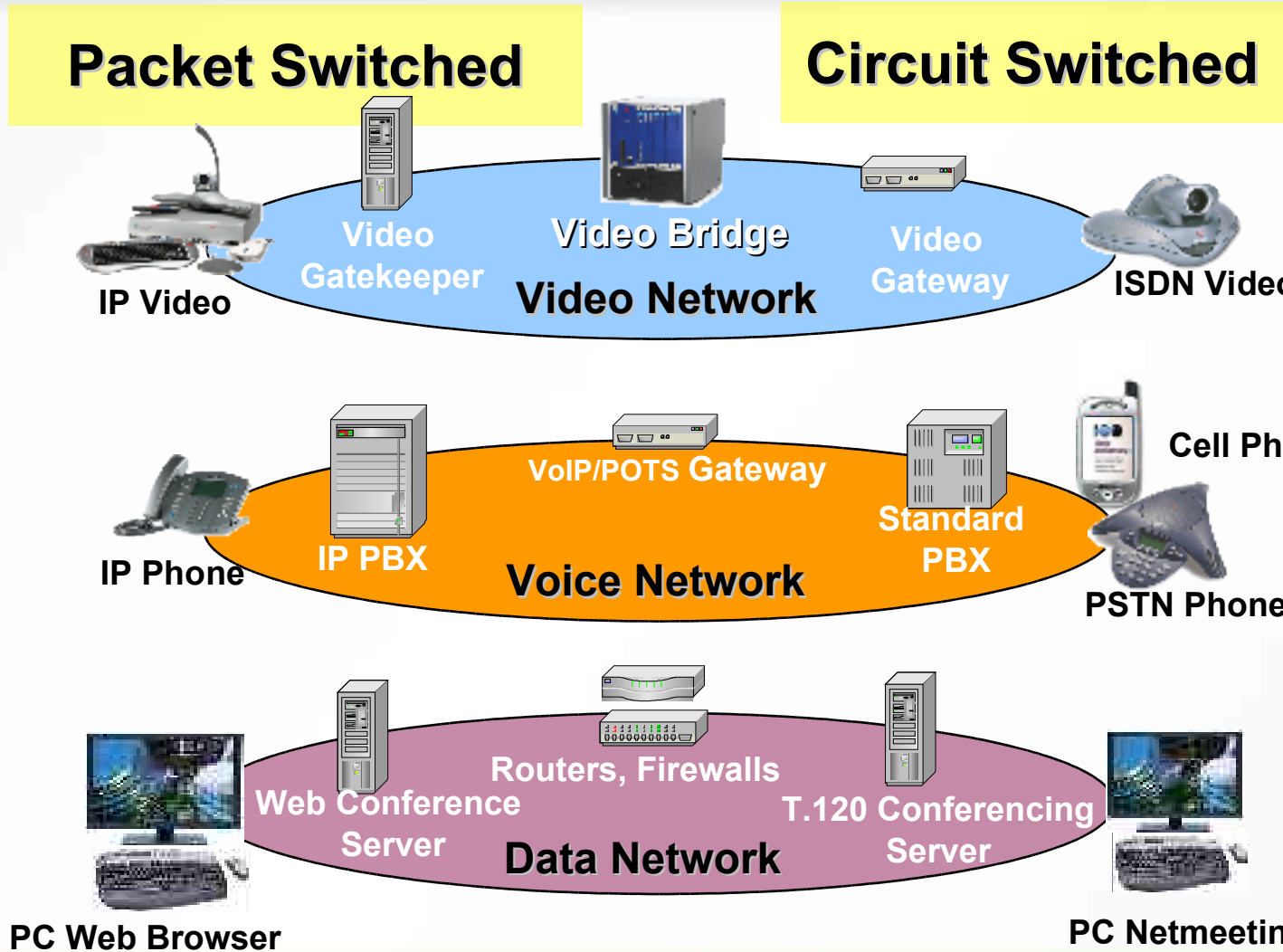

Current Architecture

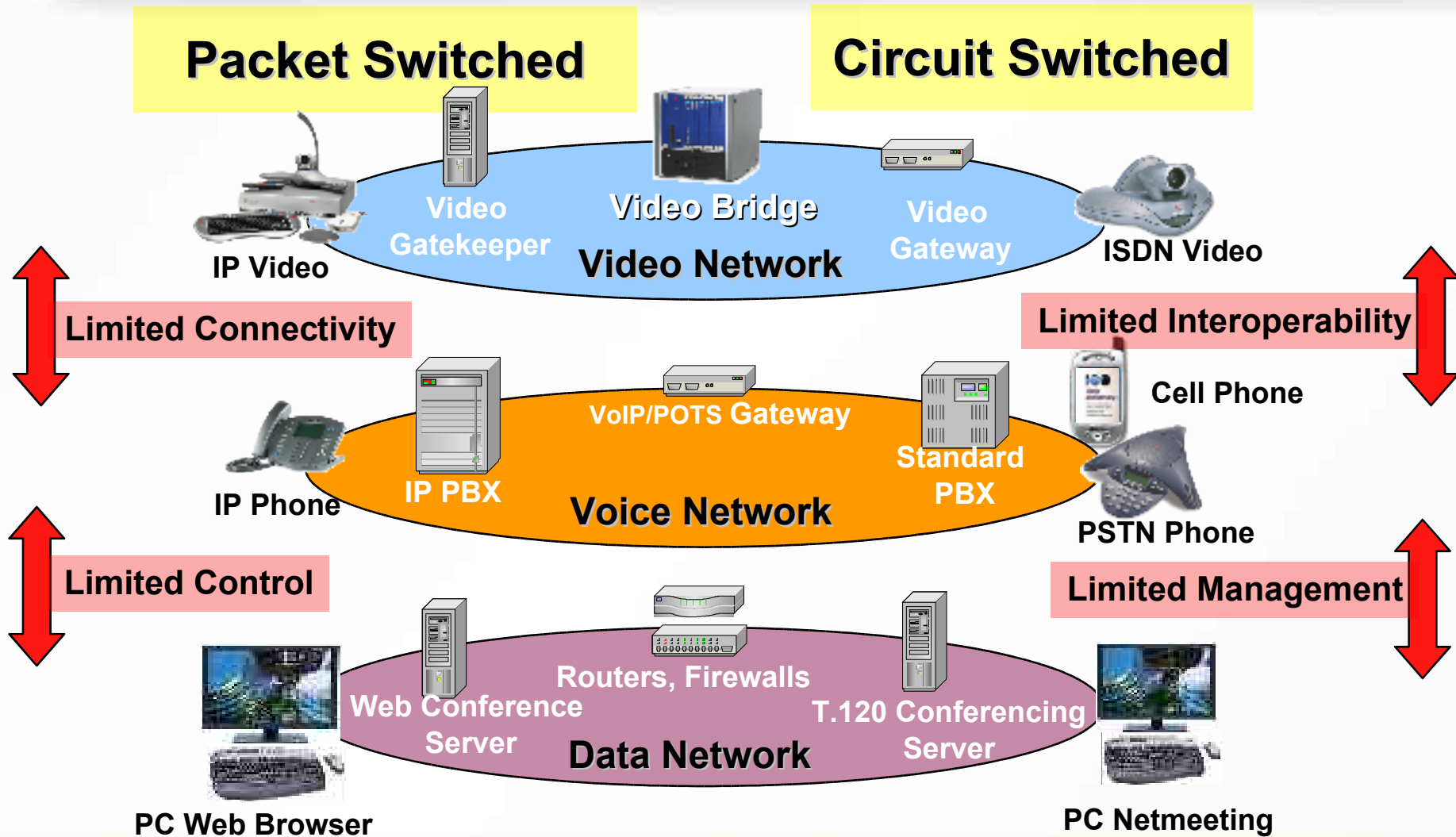

Unified Collaborative Communications

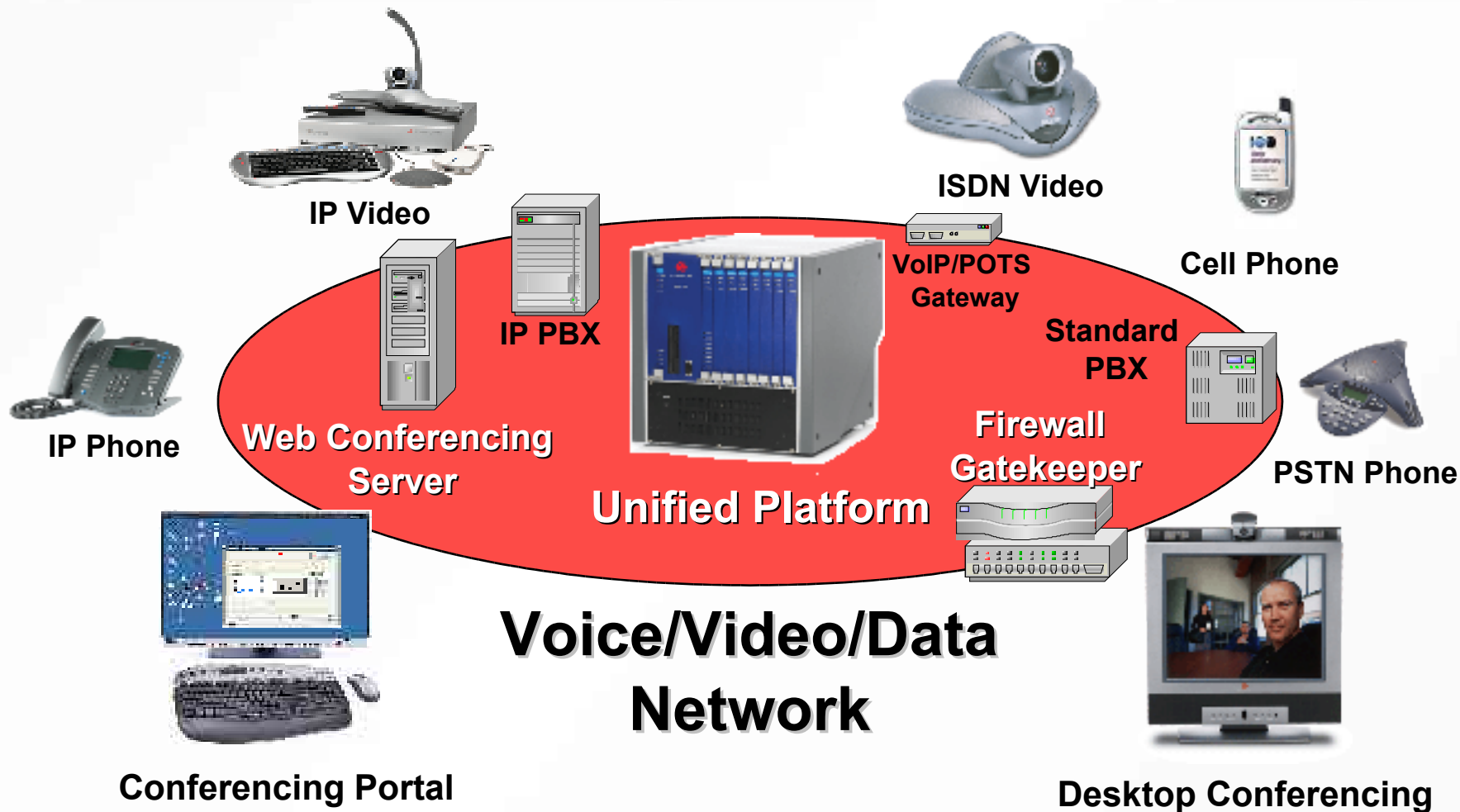

Unified Collaborative Communications

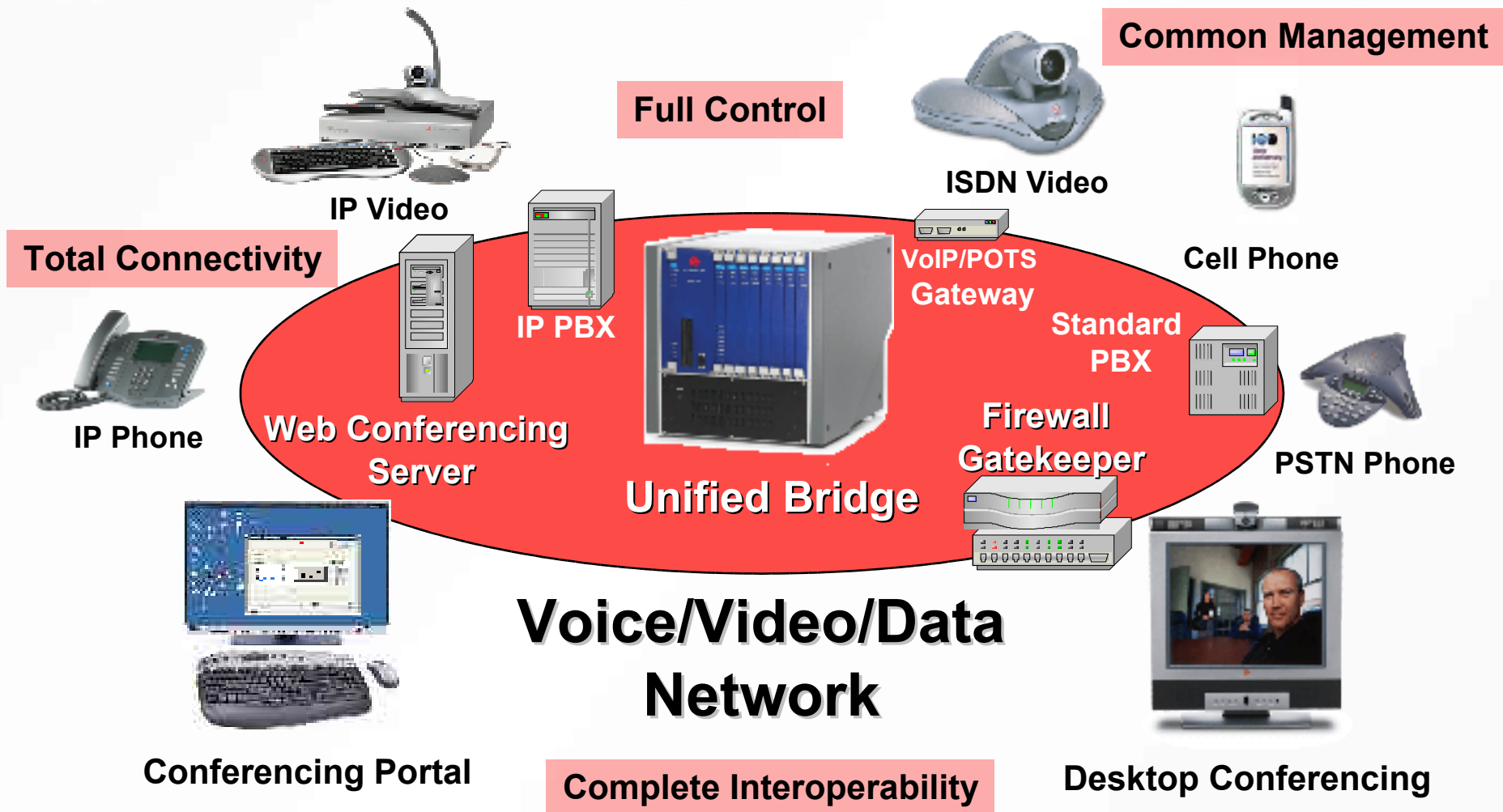

Network Requirements

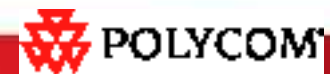

Converged Solutions –network requirements



- **Well engineered IP network**
 - **Video is a Bandwidth hog**
 - **Ensure sufficient bandwidth in the access**
 - **Broadband connection speeds close to 384 kbps give good performance for multimedia applications**
 - **Ensure adequately provisioned backbone**
 - **Methods to handle network congestion**
 - **Ability to support multicast (?)**
 - **Depends on Video application**
 - **Reduces bandwidth requirements**
 - **Increases Scalability**

Converged Solutions –network requirements



- **Provide guarantees for delay, jitter, packet loss through traffic engineering**
 - **Voice/Video VERY delay sensitive**
 - **Media Anchoring to prevent loss of audio-video synchronization**
 - **Resynchronize audio/ video timestamps in the network**
 - **Packet loss compensation**
 - **PLCs with audio codecs**
 - **insert blank video frames to compensate for video packet loss**
 - **Jitter buffer to compensate for jitter**
 - **Decide optimal size**

Converged Solutions –network requirements



- **Supports Quality of service**
 - **Prioritize voice/video packets**
 - **Real time voice/video packets receive higher priority than non-real time web traffic**
 - **Significant delay/jitter events can be avoided only by implementing a proper QoS Strategy**

Converged Solutions – network requirements



- Best Effort
 - A class of service in which the network provides no guarantees to the edge equipment
- Prioritized Queuing
 - Differentiation in the queuing of traffic for various classes of traffic
 - Assigns a priority or classification to every IP packet
 - Higher priority assigned to real-time application packets
 - Packets are sent in order of priority
- Traffic Engineered in the core:
 - MPLS
 - Other mechanisms

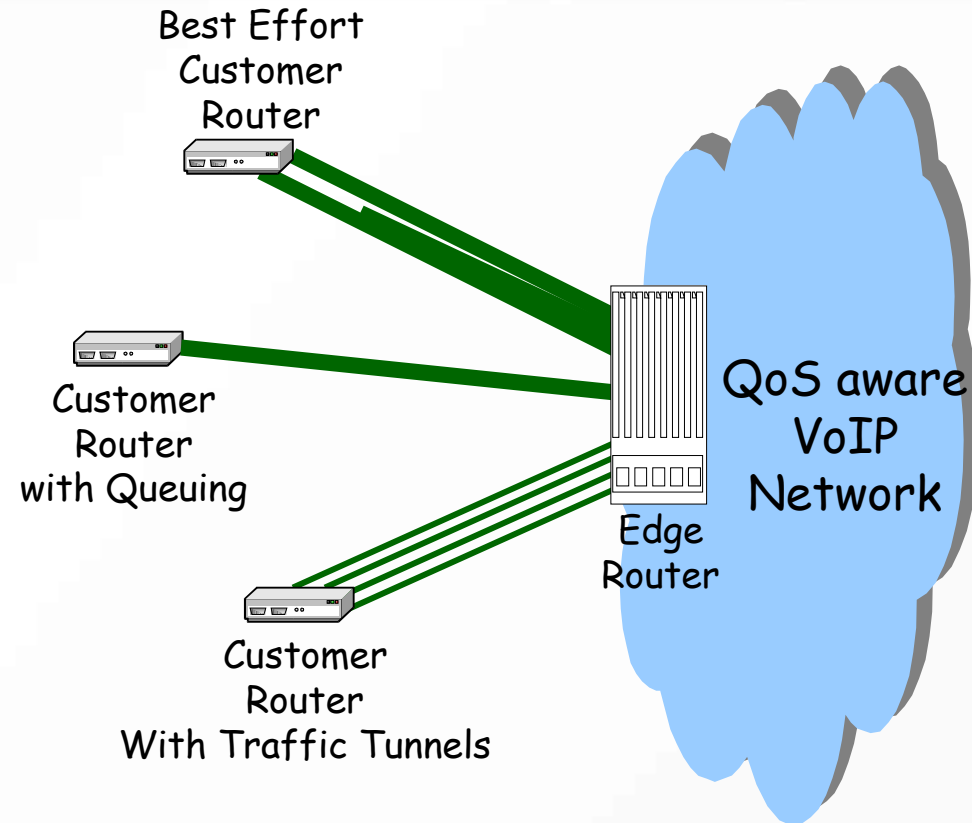

Converged Solutions – network requirements



● Call control, signaling

- H.323 & SIP is the natural order of things today
- H.323 is the existing market base
- SIP is the standard of the future – enabling new services
 - Presence, Mobility, User preferences
 - Instant multimedia communications: Text, Voice/Video/Data
 - Multiple media: Text, Voice, Video, Shared Data
 - Multiple devices: phones, PC/laptop, Handheld computers, Pagers
 - Advanced Multimedia Conferencing through app. Integration
 - SIP enables application/service integration across various collaboration domains
- Both protocols will co-exist & must interoperate

Converged Solutions – network requirements



● Transcoding

- **Various parameters to transcode**
 - **Audio codecs (G.729A, G.711)**
 - **Video Codecs (H.261, H.263, H.264)**
 - **Video bandwidths (128 kbps, 384 kbps)**
 - **Video formats (CIF, QCIF)**
 - **Video frame rates (30 fps, 14 fps)**
- **Must ensure that each participant gets his optimal capabilities**
- **Transcoding adds to delays so powerful processors must be employed**

Converged Solutions – network requirements



- **Network Security**
 - **Session-aware firewalls for two-way multimedia communication**
 - **Dynamic pinhole opening and closing**
 - **Secure packet processing and filtering**
- **Scalable elements to handle millions of voice/video/data sessions**
- **Reroute upon failures**
- **Billing for usage**
- **One management interface to manage the complete service**

Industry

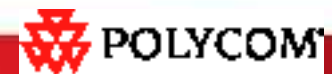

UCC Industry Momentum



	WAN / LAN	PBX / IP PBX	Voice Handset	Collaborative Applications	Video Applications	Video Endpoints	Web-conferencing	Video-conferencing
3Com	✓	✓	✓					
Avaya	✓	✓	✓		✓			✓
Cisco Systems	✓	✓	✓		✓			✓
Entis				✓				
Microsoft/PlaceWare				✓			✓	
Nortel Networks	✓	✓	✓					
Polycom			✓	✓	✓	✓	✓	✓
Raindance								✓
Sony						✓		
Spectel							✓	✓

UCC Has Support Across Major Players in The Industry

Summary

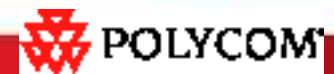

Summary



- Unified Collaborative and Multimedia solutions are becoming a reality
- Certain challenges need to be overcome
- Service Providers need to build a network infrastructure capable of handling the multimedia requirements
- Vendors must support standards based technology to enable wide adoptability of multimedia applications
- Universal Collaborative and Multimedia solutions will make communication much easier!!!

